



US00D371846S

United States Patent [19]

[11] Patent Number: **Des. 371,846**

Lurie et al.

[45] Date of Patent: ****Jul. 16, 1996**

- [54] **NURSING BOTTLE AIR ELIMINATOR**
- [75] Inventors: **George S. Lurie**, 130 Buckminster Rd., Brookline, Mass. 02146; **Keith D. Patterson**, Providence, R.I.
- [73] Assignee: **George S. Lurie**, Brookline, Mass.
- [**] Term: **14 Years**
- [21] Appl. No.: **41,261**
- [22] Filed: **Jul. 10, 1995**

- 3,134,494 5/1964 Quinn .
- 3,221,891 12/1965 Snow .
- 3,648,873 3/1972 Grobbel .
- 3,822,806 7/1974 Grimes .
- 4,101,044 7/1978 Paquette et al. .
- 4,726,553 2/1988 Wischusen .
- 4,796,767 1/1989 McKeown .
- 4,880,125 11/1989 LeBeau .
- 4,979,629 12/1990 Askerneese .
- 5,033,631 7/1991 Nightingale .
- 5,109,996 5/1992 Sullivan .

Primary Examiner—Stella Reid
Attorney, Agent, or Firm—Steven N. Fox

Related U.S. Application Data

- [63] Continuation of Ser. No. 366,495, Dec. 30, 1994.
- [52] **U.S. Cl.** **D24/193**
- [58] **Field of Search** D24/193; 215/11.1–11.6

[57] CLAIM

The ornamental design of a “nursing bottle air eliminator”, as shown and described.

[56] References Cited

U.S. PATENT DOCUMENTS

- | | | | | |
|------------|---------|------------|-------|---------|
| D. 338,531 | 8/1993 | Howell | | D24/193 |
| D. 352,785 | 11/1994 | Fitzgerald | | D24/193 |
| D. 353,006 | 11/1994 | Korzenko | | D24/193 |
| D. 363,351 | 10/1995 | Shelter | | D24/193 |
| 2,016,097 | 10/1935 | Parsons | . | |
| 2,670,085 | 2/1954 | Sorrentino | . | |

DESCRIPTION

FIG. 1 is an end view of the present invention; FIG. 2 is a top view of the present invention; FIG. 3 is a bottom view of the present invention; FIG. 4 is a side view of the present invention, the opposite side view being identical thereto; and, FIG. 5 is an end view of the present invention opposite the end view of FIG. 1.

1 Claim, 2 Drawing Sheets

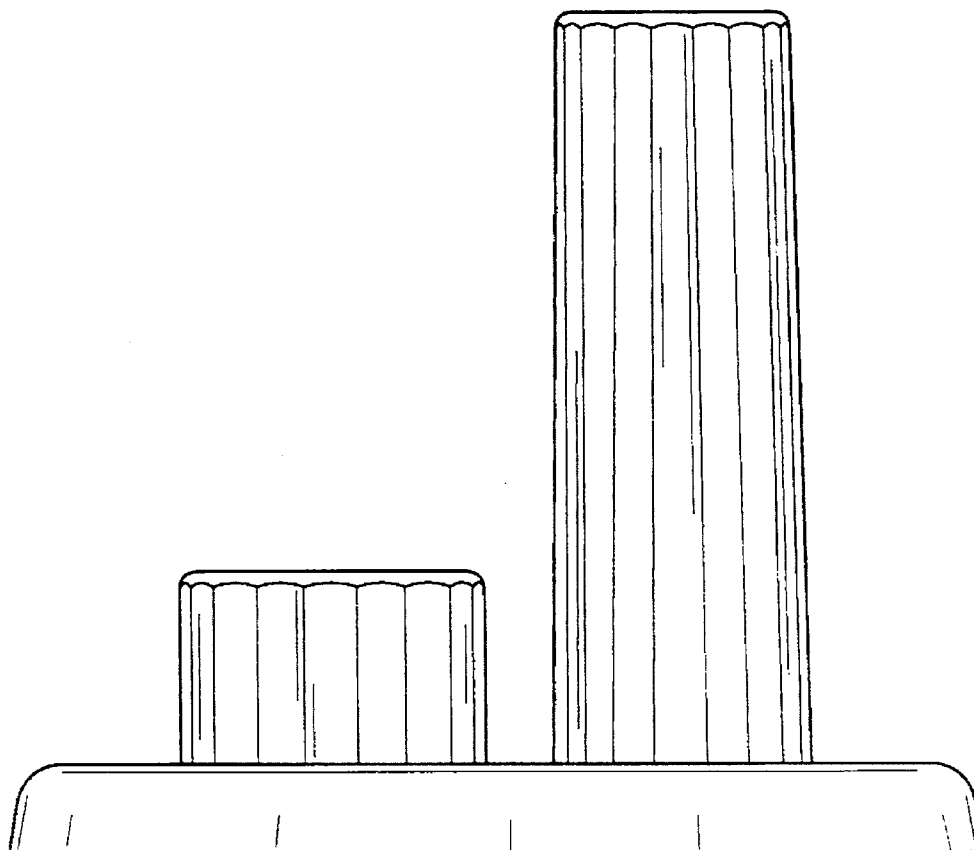

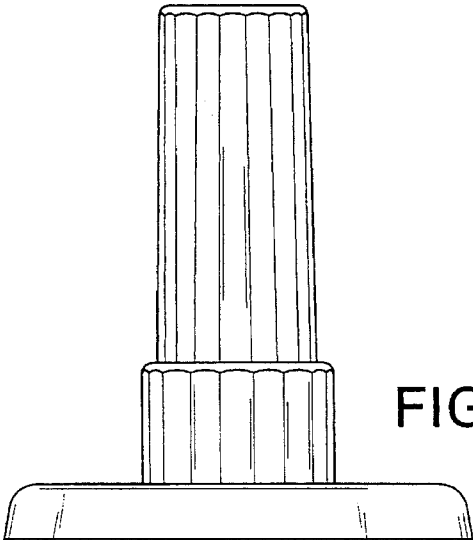

FIG. 1

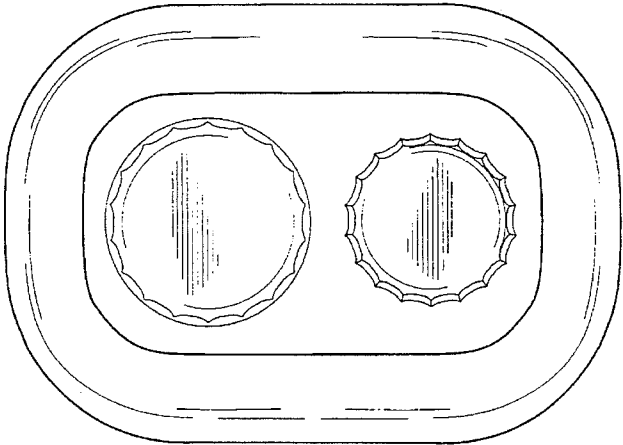

FIG. 2

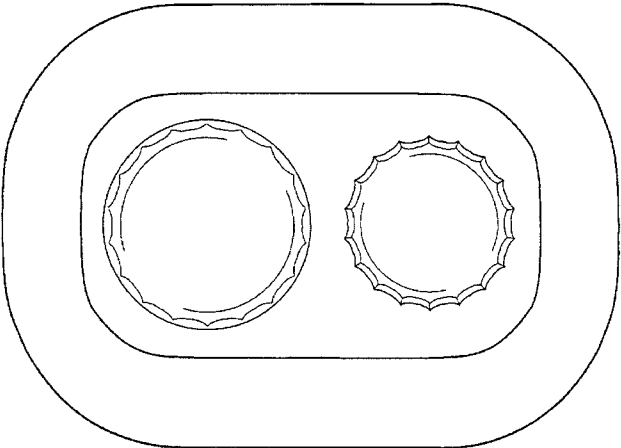

FIG. 3

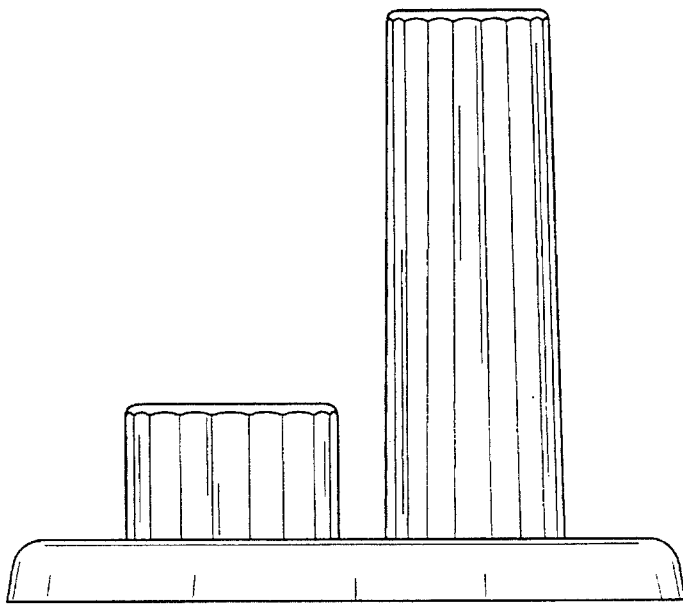

FIG. 4

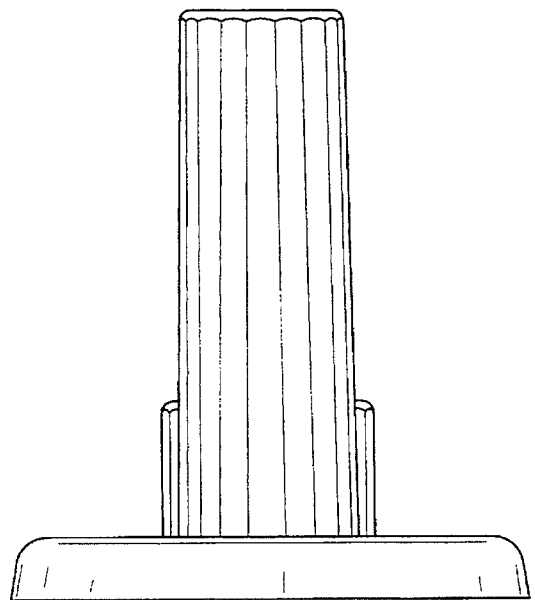

FIG. 5